

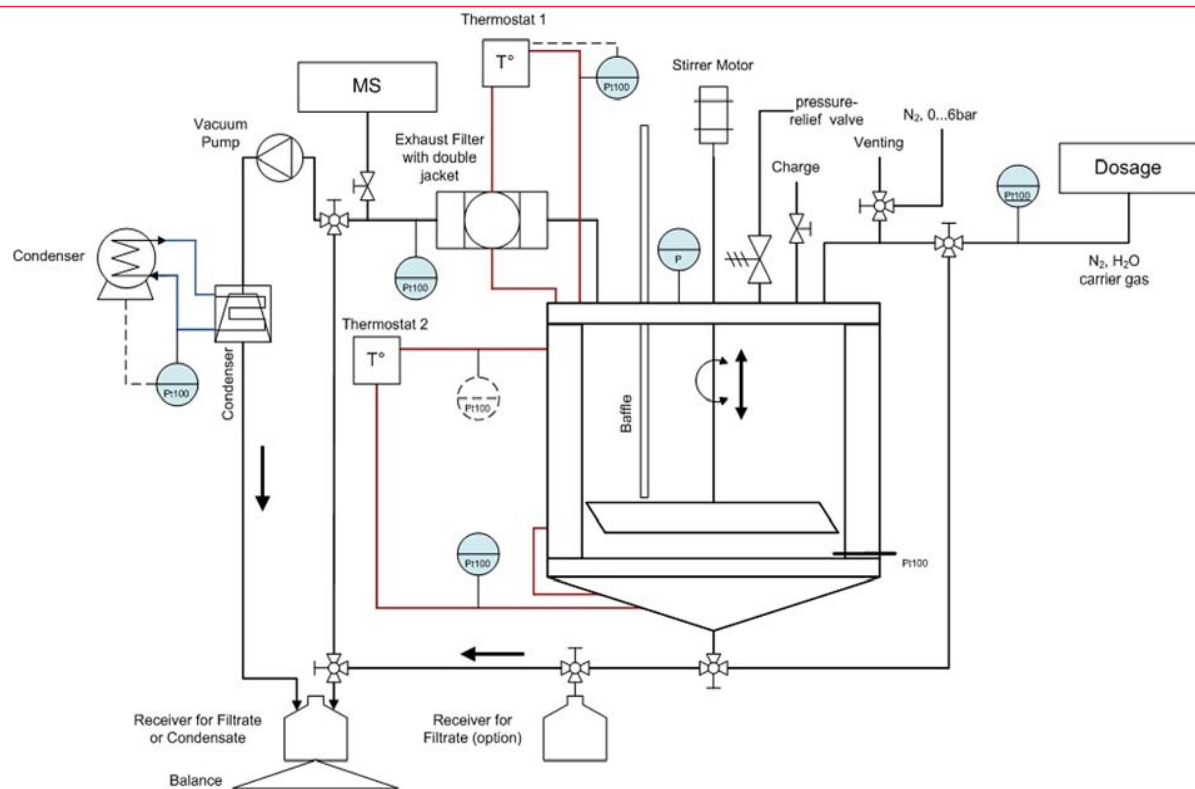

Block Diagram



FiDry - Technical Data

Filter Vessel	Volume and pressure range	0.5L, 1L, (optionally 2L); 0 to 6 bar (2L 3 bar)
	Material	Borosilicate Glass, cover and bottom plate stainless steel DIN 1.4571 Seals: Kalrez, PFA coated silicon
	Heating / Cooling system	Up to two external thermostats for temperature control of bottom / jacket and cover plate separately
	Temperature range	-20°C bis +150°C
	Agitator	1 – 600 rpm, torque 10Nm, distance between agitator paddle and vessel wall <2 mm. Agitator direction reversible. Lip-sealed agitator axle with additional wiper ring
	Linear Motor	Total travel for agitator 200mm. Adjustment speed 10mm per min up to 500mm per minute
	Filter	Filter cloth or filter plate with up to 5mm thickness
	Lowering of vessel	250 mm
	Turning of vessel	up to 180°
Accessories	Vacuum Control	Automatic pressure gradient based on set point value. Final vacuum <10 mbar
	Moisturizing unit	Bronkhorst CEM device (Controlled Evaporator and Mixing)
	Condensable Solvent Measurement	Balance 8 kg, with 0.1g resolution
	Exhaust unit	With heated dust filter
Technical Data	Environmental Temperature	10...35°C
	Mains supply	3x400 VAC, 10 A, 50 or 60 Hz, 3-phase, uninterrupted
	Dimensions	H x W x D 2100 x 1200 x 700 mm
Control System		Personal Computer with FlexySys process control system and SysGraph for graphical data analysis

Technical changes can be made at any time

Copyright by SYSTAG (2010)

Filename: A3e_FilDry_Flyer_1e4.pmd

FiDry

Laboratory Device for the investigation of filtration and drying processes for the chemical process development

Usage as an agitated filter dryer

- Filtration under controlled Nitrogen pressure
- Washing of the filter cake by displacement or suspending wash
- Dual purpose agitator with lift automatic
- During the filtration and washing step, the stirrer is used to smooth down the cake surface to prevent cracking of the filter cake
- During the drying step, the stirrer is used to break the filter cake and to suppress lump formation

Usage as a paddle dryer

- Simple exchange of the filter plate for a base plate and insertion of a baffle
- Direct loading of the good into the lowered vessel
- Drying under controlled vacuum and temperature condition

Further advantages

- **Logging** of all physical Process Data
- **Filtration:** Tracking of the filtration speed by weighing the mother liquid during the filtration. (For calculation of the filtration constant)
- **Drying:** Tracking of the drying process by weighing of the recondensed solvent
- **Control System:** Equipment with specific user interface. Manual or recipe control process control. Intuitive and easy to learn recipe editor (drag and drop) and therefore short initial training duration. Automatic Lab Journal based on Microsoft Word. Worldwide remote support via Internet.
- Easy definition of **SOP** (standard operation procedures)



FilDry System

at a glance

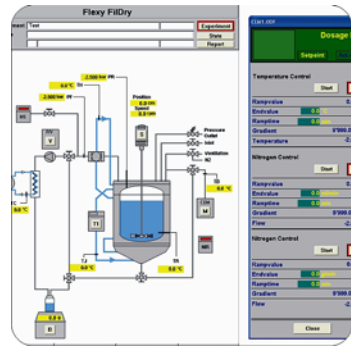

Synoptic User Interface

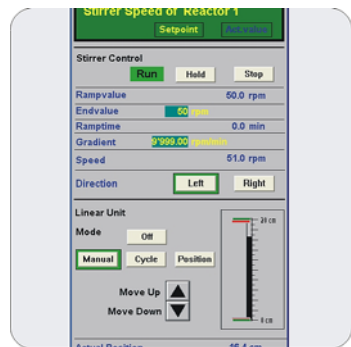

Agitator control with agitator speed, agitator direction and agitator lift

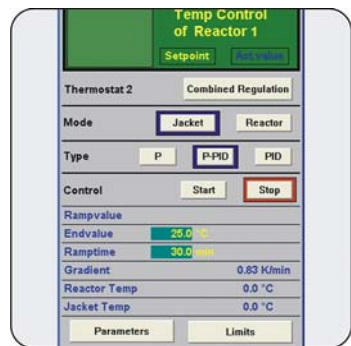

Temperature Control for inside temperature and jacket temperature control

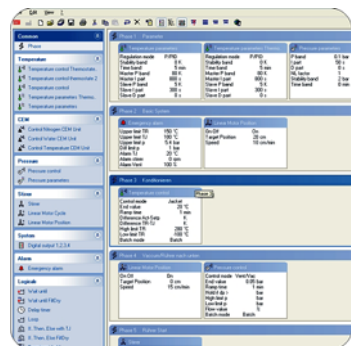

Flexible and easy to use recipe editor



Easy loading of product into the lowered and tilted vessel



Equally easy unloading



Cover plate with large filler neck



Filtration bottom with subagent filter plate. Handy assembling with rotated vessel